

# TB 9-5120-202-24

CHANGE 1

DEPARTMENT OF THE ARMY TECHNICAL BULLETIN

---

## CALIBRATION PROCEDURE FOR TORQUE WRENCHES AND TORQUE SCREWDRIVERS (GENERAL)

---

Headquarters, Department of the Army, Washington, DC

14 August 2008

*Distribution Statement A: Approved for public release; distribution is unlimited.*

---

TB 9-5120-202-24, 20 June 2007, is changed as follows:

1. Remove old pages and insert new pages as indicated below. New or changed material is indicated by a vertical bar in the margin of the page.

**Remove Pages**  
13 and 14 BLANK

**Insert Pages**  
13 and 14 BLANK

2. File this change sheet in front of the publication for reference purposes.

By Order of the Secretary of the Army:

GEORGE W. CASEY, JR.  
*General, United States Army*  
*Chief of Staff*

Official



JOYCE E. MORROW  
*Administrative Assistant to the  
Secretary of the Army*

0817017

Distribution:

To be distributed in accordance with IDN 342077, requirements for calibration procedure  
TB 9-5120-202-24.



# \*TB 9-5120-202-24

DEPARTMENT OF THE ARMY TECHNICAL BULLETIN

## CALIBRATION PROCEDURE FOR TORQUE WRENCHES AND TORQUE SCREWDRIVERS (GENERAL)

Headquarters, Department of the Army, Washington, DC  
20 June 2007

*Distribution Statement A: Approved for public release; distribution is unlimited.*

### REPORTING OF ERRORS AND RECOMMENDING IMPROVEMENTS

You can improve this manual. If you find any mistakes or if you know of a way to improve these procedures, please let us know. Mail your letter or DA Form 2028 (Recommended Changes to Publications and Blank Forms) directly to Commander, US Army Aviation and Missile Command, ATTN: AMSAM-MMC-MA-NP, Redstone Arsenal, AL 35898-5000. A reply will be furnished to you. You may also provide DA Form 2028 information to AMCOM via e-mail, fax, or the World Wide Web. Our FAX number is: DSN 788-6546 or Commercial 256-842-6546. Our e-mail address is: [2028@redstone.army.mil](mailto:2028@redstone.army.mil). Instructions for sending an electronic 2028 may be found at the back of this manual. For the World Wide Web, use: <https://amcom2028.redstone.army.mil>.

SECTION		Paragraph	Page
I.	IDENTIFICATION AND DESCRIPTION		
	Test instrument identification .....	1	2
	Forms, records, and reports.....	2	2
	Calibration description .....	3	2
II.	EQUIPMENT REQUIREMENTS		
	Equipment required.....	4	7
	Accessories required.....	5	7
III.	CALIBRATION PROCESS		
	Preliminary instructions .....	6	8
	Equipment setup.....	7	8
	Accuracy (12 in-lbs (192 in-oz) or greater) .....	8	11
	Accuracy (12 in-lbs (192 in-oz) or less)	9	13
	Final procedure .....	10	13
	Appendix A .....		A-1

\*This bulletin supersedes TB 9-5120-202-35, dated 28 April 2006, including all changes.

**SECTION I  
IDENTIFICATION AND DESCRIPTION**

**1. Test Instrument Identification.** This bulletin provides instructions for the calibration of Torque Wrenches and Torque Screwdrivers (General). The manufacturer’s manual and Federal Specifications, GGG-W-00686C (GSA-FSS) were used as the prime data sources in compiling these instructions. The equipment being calibrated will be referred to as the TI (test instrument) throughout this bulletin.

**a. Model Variations.** Variations among models are described in table 2.

**b. Time and Technique.** The time required for this calibration is approximately .5 hours, using the physical technique.

**2. Forms, Records, and Reports**

**a.** Forms, records, and reports required for calibration personnel at all levels are prescribed by TB 750-25.

**b.** Adjustments to be reported are designated (R) at the end of the sentence in which they appear. When adjustments are in tables the (R) follows the designated adjustment. Report only those adjustments made and designated with (R).

**3. Calibration Description.** TI parameters and performance specifications which pertain to this calibration are listed in table 1.

Table 1. Calibration Description

Test instrument parameters	Performance specifications
Torque wrenches: Type I, II, and V	Range: 0 to 2000 ft-lb Accuracy: $\pm 4\%$ of nominal reading from 20% of FS to FS <sup>1</sup>
Type III  Type IV	Accuracy: CW: Same as Type I and II CCW: $\pm 6\%$ of nominal reading from 20% of FS <sup>1</sup> Accuracy: $\pm 5\%$ of setting or as specified below, whichever is greater from 20% of FS to FS Size 1: $\pm 1/2$ in-oz Size 2: $\pm 1/2$ in-lb
Torque screwdrivers	Range: 0 to 1600 in-oz and 0 to 100 in-lb. Accuracy: See appendix A

<sup>1</sup>No accuracy requirement from 0 to 20% of scale of wrench.

Table 2. Types, Classes and Styles of Torque Wrenches

Type	Class	Style
Type I - Deflecting beam	Class 1 - Indicator plate	Style A: Direct reading (figure 1) Style B: Direct reading with audible signal (figure 2)
	Class 2 - Indicator dial	Style A: Direct reading (figure 3) Style B: Direct reading with audible signal (figure 4)
Type II - Rigid case with indicator dial	---	Style A: Direct reading (figure 5) Style B: Direct reading, presetting audible signal (figure 6) Style C: Direct reading with flashlight signal (figure 7)
Type III - Rigid case, micrometer presetting, audible signal	Class 1 - Plain head (figure 8)	---
	Class 2 - Ratchet, reversible head (figure 9)	---
Type IV - Tee handle, rigid case, ratchet, audible signal	Class 1 - Torque set and sealed (figure 10)	---
	Class 2 - Torque set adjustable (figure 11)	---
Type V - Rigid case preset audible signal (figure 12)	---	---
Torque screwdriver	---	Direct reading (figure 13)

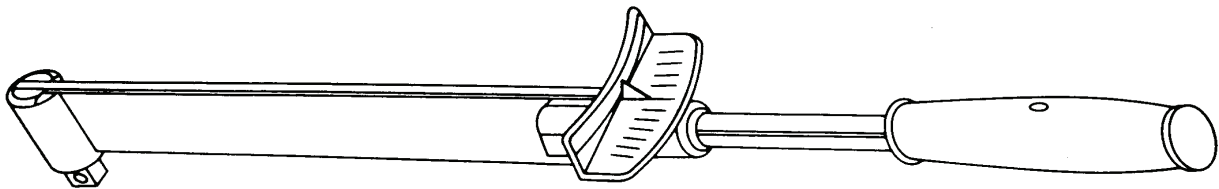

Figure 1. Type I, class 1, style A torque wrench, deflecting beam with indicator plate (direct reading).

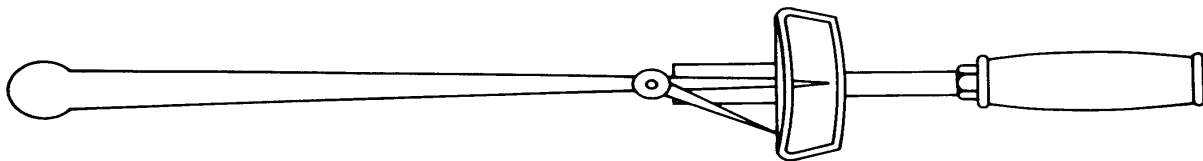

Figure 2. Type I, class 1, style B torque wrench, deflecting beam with indicator plate (direct reading with audible signal).

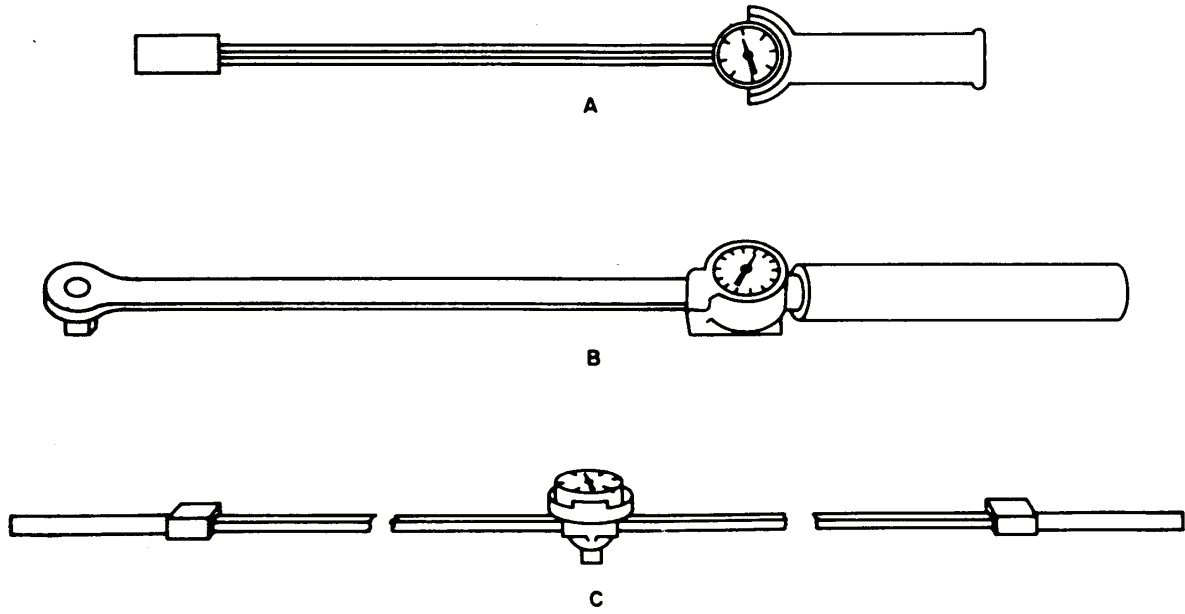

Figure 3. Type I, class 2, style A torque wrenches, deflecting beam with indicating dial (direct reading).

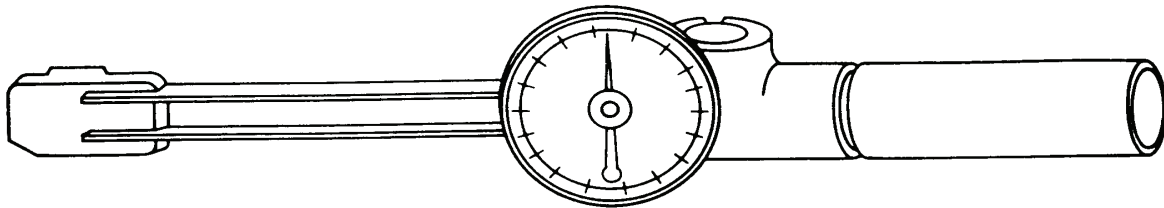

Figure 4. Type I, class 2, style B torque wrench, deflecting beam with indicating dial (direct reading with audible signal).

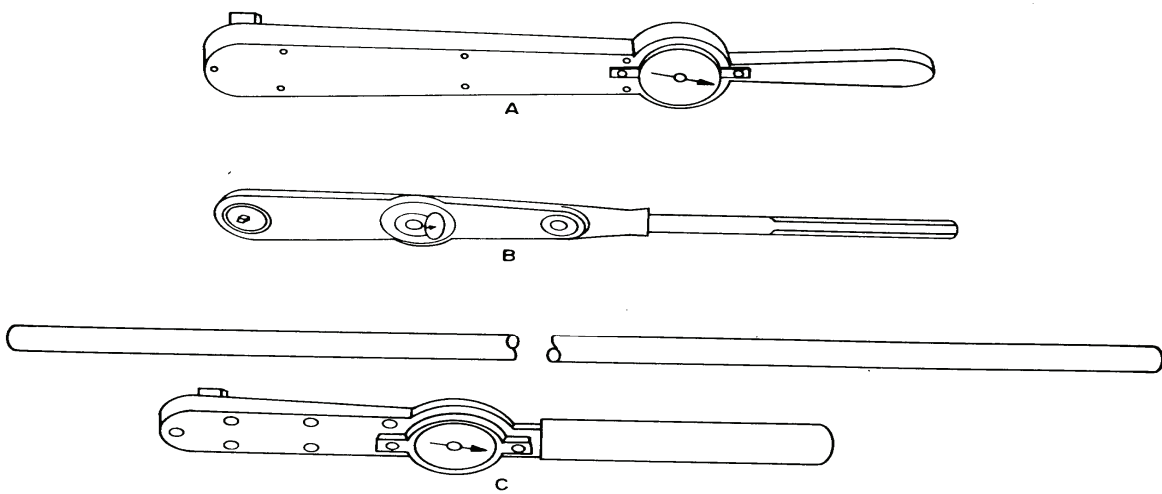

Figure 5. Type II, style A torque wrench, rigid case with indicator dial (direct reading).

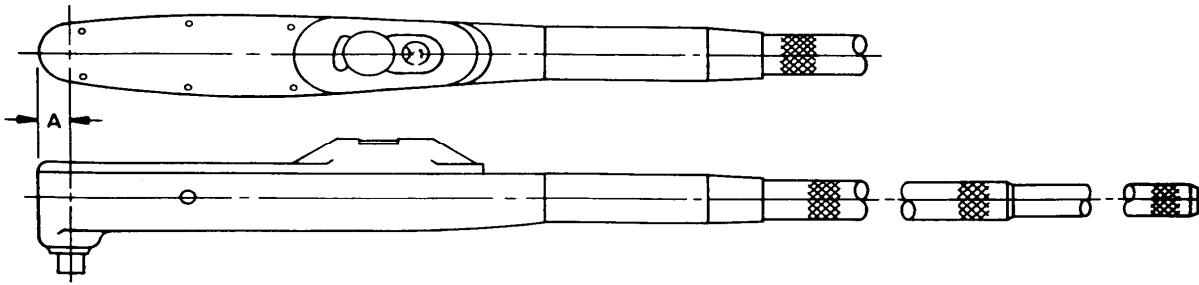

Figure 6. Type II, style B torque wrench, rigid case with indicator dial, presetting torque dial (direct reading with audible signal).

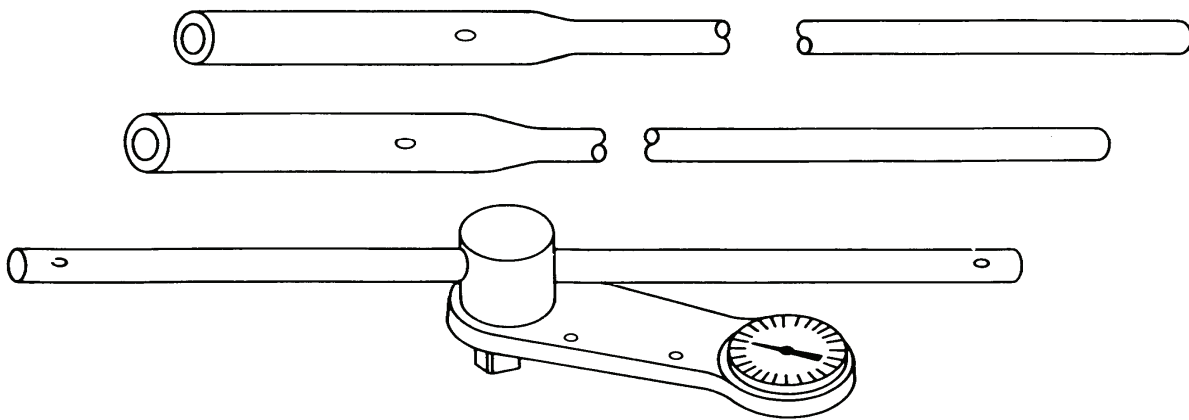

Figure 7. Type II, style C torque wrench, rigid case with presetting dial (direct reading with flashlight signal).

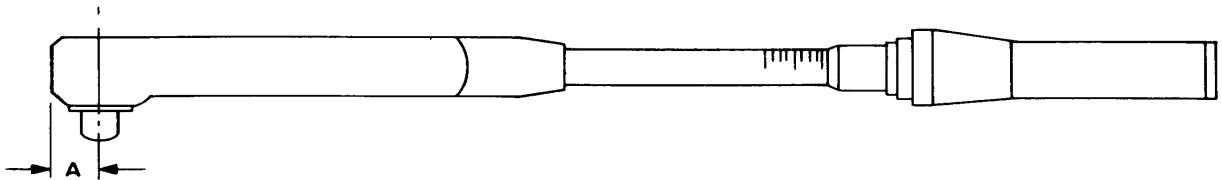

Figure 8. Type III, class 1 torque wrench, rigid case, micrometer-style torque presetting, audible signal, plain head.

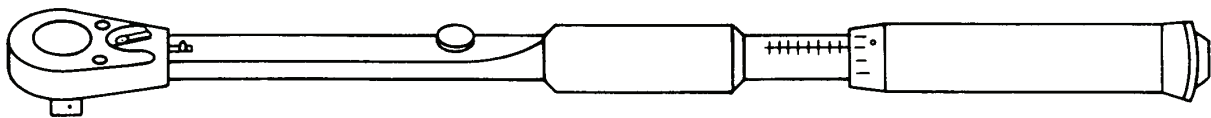

Figure 9. Type III, class 2 torque wrench, rigid case, micrometer-style torque presetting, audible signal, ratchet reversible head.

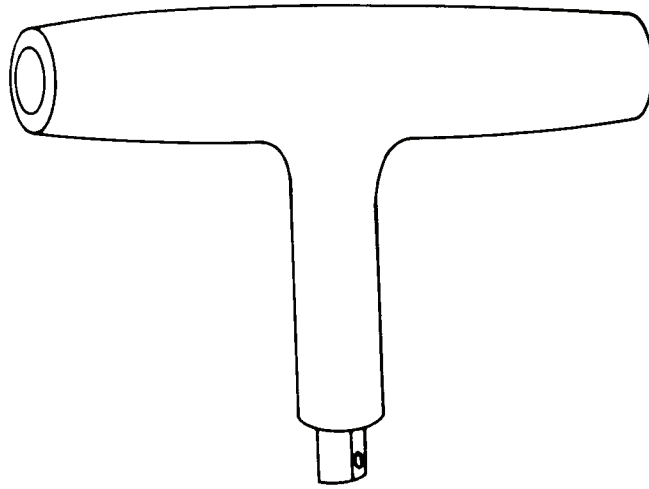

Figure 10. Type IV, class 1 torque wrench, tee handle, rigid case, ratcheting, audible signal, torque value set and sealed.

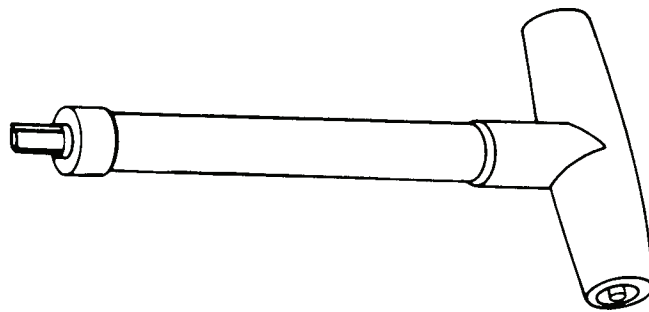

Figure 11. Type IV, class 2 torque wrench, tee handle, rigid case, ratcheting, audible signal, torque value setting, adjustable.

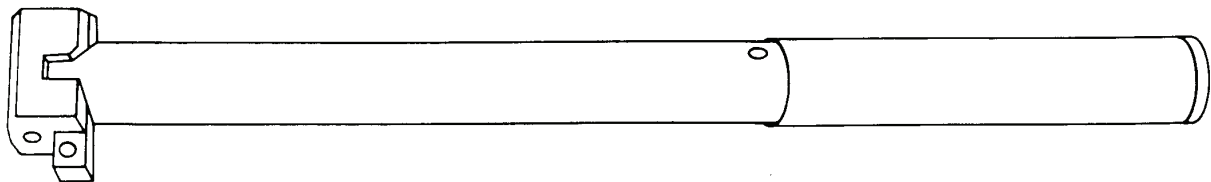

Figure 12. Type V torque wrench, rigid case, preset torque, audible signal.



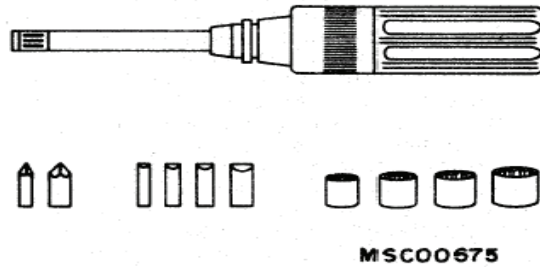

Figure 13. Torque screwdriver (direct reading, typical).

## SECTION II EQUIPMENT REQUIREMENTS

**4. Equipment Required.** Table 3 identifies the specific equipment to be used in this calibration procedure. This equipment is issued with Secondary Transfer Calibration Standards Set AN/GSM-286; AN/GSM-287; AN/GSM-421; or AN/GSM-705. Alternate items may be used by the calibrating activity. The items selected must be verified to perform satisfactorily prior to use and must bear evidence of current calibration. The equipment must meet or exceed the minimum use specifications listed in table 3. The accuracies listed in table 3 provide a four-to-one ratio between the standard and TI. Where the four-to-one ratio cannot be met, the actual accuracy of the equipment selected is shown in parenthesis.

**5. Accessories Required.** The accessories required for this calibration are common usage accessories, issued as indicated in paragraph 4 above, and are not listed in this calibration procedure.

Table 3. Minimum Specifications of Equipment Required

Common name	Minimum use specifications	Manufacturer and model (part number)
FORCE/TORQUE INDICATOR	Range: $\pm 0.1$ -3.06 mv/v Accuracy: $\pm 0.03\%$ indication	HBM, Model MGCplus (13589298)
TORQUE CELL NO. 1	Range: 0 to 60 in-lb Accuracy: $\pm 0.5\%$ applied torque from 20% FS to FS $\pm 0.5\%$ of 20% FS below 20% FS	Lebow Associates, Model 2133-124-5 (MIS-26485, Type 1, CL1)
TORQUE CELL NO. 2	Range: 0 to 20 ft-lb Accuracy: $\pm 0.5\%$ applied torque from 20% FS to FS $\pm 0.5\%$ of 20% FS below 20% FS	Lebow Associates, Model 2133-124-20 (MIS-26485, Type 1, CL2)

Table 3. Minimum Specifications of Equipment Required - Continued

Common name	Minimum use specifications	Manufacturer and model (part number)
TORQUE CELL NO. 3	Range: 0 to 100 ft-lb Accuracy: $\pm 0.5\%$ applied torque from 20% FS to FS $\pm 0.5\%$ of 20% FS below 20% FS	Lebow Associates, Model 2133-125 (MIS-26485, Type 1, CL3)
TORQUE CELL NO. 4	Range: 0 to 500 ft-lb Accuracy: $\pm 0.5\%$ applied torque from 20% FS to FS $\pm 0.5\%$ of 20% FS below 20% FS	Lebow Associates, Model 2133-126 (MIS-26485, Type 1, CL4)
TORQUE CELL NO. 5	Range: 0 to 1000 ft-lb Accuracy: $\pm 0.5\%$ applied torque from 20% FS to FS $\pm 0.5\%$ of 20% FS below 20% FS	Lebow Associates, Model 2133-127 (MIS-26485, Type 1, CL5)
TORQUE TESTER	Range: 20 to 200 in-oz. Accuracy: $\pm 0.5\%$ applied torque	AWS3002 (MIS-45850)

### SECTION III CALIBRATION PROCESS

#### 6. Preliminary Instructions

a. The instructions outlined in paragraphs 6 and 7 are preparatory to the calibration process. Personnel should become familiar with the entire bulletin before beginning the calibration.

b. Items of equipment used in this procedure are referenced within the text by common name as listed in table 3.

c. Unless otherwise specified, verify the result of each test and, whenever the test requirement is not met, take corrective action before continuing with the calibration. Adjustments required to calibrate the TI are included in this procedure. Additional maintenance information is contained in the manufacturer's manual for these TIs.

d. Unless otherwise specified, all controls and control settings refer to the TI.

#### 7. Equipment Setup





##### WARNING

HIGH VOLTAGE is used or exposed during the performance of this calibration. DEATH ON CONTACT may result if personnel fail to observe safety precautions. REDUCE OUTPUT(S) to minimum after each step within the performance check where applicable.

- a. Remove TI from case.
- b. Visually check TI for bent or damaged pointers or needles. Pointers or needles must have freedom of movement during torque.
- c. Remove any dirt or grime that may have accumulated around the trigger or ratchet mechanism by using a stiff, clean brush and wiping with clean rag.
- d. Visually check square drive for roundness of corners.
- e. Check head and yoke for looseness from measuring element.
- f. Secure holding fixture or torque adapter to a stable, rigid work surface.
- g. Zero TI, if applicable.

**NOTE**

This procedure normally covers calibration in the clockwise direction. A counterclockwise calibration can be accomplished by reversing directions outlined in each performance check. It will be necessary to torque the torque cell full-scale three times, in the direction of intended operation, prior to calibration. Torque wrenches will be calibrated by applying increasing torque only in the clockwise direction, unless counterclockwise direction is specifically requested by owner/user.

- h. Allow equipment to stabilize at ambient temperature.
- i. TIs with ranges of 12 in-lbs (192 in-oz) or less; connect torque tester to a 115 V ac power source. Set power switch to **ON** and allow unit to warm-up for 30 minutes.
- j. Perform **k** through **q** below for TIs with ranges of 12 in-lbs (192 in-oz) or greater.
- k. Connect cable supplied with force/torque indicator to appropriate connector on force/torque indicator and applicable torque cell.
- l. Attach torque cell to holding fixture or torque adapter. Position torque cell with the cable hanging down at the six or seven o'clock position.
- m. Connect force/torque indicator to a 115 V ac power source. Set power switch to **ON** and allow unit to warm-up for 30 minutes. Select channel **3** by using the **CHANNEL +** and **-** keys.
- n. Press the F4 key on the force/torque indicator until you see the   soft keys. Press the   soft keys as necessary to select the torque cell for the TI range, direction, and serial number being calibrated.
- o. Press the F4 key on the force/torque indicator until you see the **UNIT** soft key. Press the **UNIT** soft key as necessary to select the appropriate units to display.

**NOTE**

When possible use one torque cell to calibrate entire range of TI.

**p.** Exercise torque cell as described in (1) through (5) below:

- (1) Attach socket wrench (part of adapter set) to torque cell.
- (2) Slowly apply torque to torque cell in clockwise direction until full-scale is reached.

**NOTE**

The indicator will indicate + (positive) for clockwise torque and - (negative) for counterclockwise torque.

- (3) Slowly release torque until only tare torque of wrench is applied.
- (4) Repeat (2) and (3) above two more times.
- (5) Remove socket wrench from torque cell.

**q.** Exercise TI as described in (1) through (5) below:

- (1) Attach TI to torque cell.
- (2) Slowly apply torque to TI and torque cell in a clockwise direction for full-scale indication on TI. (Ensure that torque cell is not over torqued).
- (3) Slowly release torque until only tare torque of TI is applied.
- (4) Repeat (2) and (3) above two more times.
- (5) Remove TI from torque cell.

**NOTE**

When applied torque changes from clockwise to counterclockwise, repeat technique of steps **p** and **q** above for counterclockwise.

**NOTE**

The calibration point must be approached in the direction of increasing torque. For higher capacity wrenches, loader should be used to apply a constant torque.

**NOTE**

Some micrometer preset torque wrenches indicate when the set torque has been reached by momentary release action of the drive for a few degrees. An audible "snap" signal may also be present at high torque settings.

**NOTE**

Throughout this procedure use torque cell with adapters appropriate to TI range.

**8. Accuracy (12 in-lbs (192 in-oz) or greater)**

**a. Performance Check**

(1) Select cardinal point of 20 percent of maximum range of TI and if necessary set the torque wrench.

(2) Press the F4 key on the force/torque indicator until you see →0← as soft key. Press the →0← soft key to zero force/torque indicator.

**NOTE**

Force/torque indicator must be in the **GROSS** mode before it can be zeroed.

**NOTE**

Use the appropriate note for the TI being calibrated. Using the **SIGNAL ▲▼** select the **GROSS** mode of operation. If the TI is the audible (snap) type then use the **SIGNAL ▲▼** to select the **1stPeakHold** mode.

(3) Insert TI in applicable torque cell, using adapter as required. Insert in horizontal position for clockwise torque. Perform applicable note below for the TI that you are calibrating.

**NOTE**

**Torque Wrench, Direct Reading:** (figures 1, 3, and 5). Gradually apply perpendicular force on handle of TI until indication in (1) above is obtained.

**NOTE**

**Torque Wrench, Direct Reading with Audible Signal:** (figures 2, 4, and 6). Adjust trigger finger of sensory signaling mechanism on TI to point selected in (1) above. The pointer tip and not the trigger finger is the reference which must be used when adjusting the sensory signaling mechanisms. Gradually apply perpendicular force on handle of TI until sharp audible sound is heard and an impulse is felt in hand. Stop applying force at this point.

**NOTE**

**Torque Wrench, Direct Reading with Flashlight Signal:** (figure 7). Check standard dry-cell battery for possible current failure in flashlight attachment. Gradually apply perpendicular force on handle of TI until needle on indicator dial reaches preset pin, making contact and lighting bulb. Stop applying force at this point.

**NOTE**

**Torque Wrench, Audible Signal, Micrometer Preset:** (figures 8 and 9). These two classes of torque wrenches differ only in that one contains a ratchet mechanism enclosed in the drive head. The ratchet is a reversible mechanism and operates by manual movement of a lever. Gradually apply perpendicular force on handle of TI until audible signal (snap) is heard. Stop applying force at this point.

**NOTE**

**Torque Wrench, Audible Signal, Tee Handle Preset** (figure 10). Note torque value setting on handle of TI. Gradually apply rotational force on handle of TI until sharp audible snap is heard. Stop applying force at this point.

**NOTE**

**Torque Wrench, Audible Signal, Tee Handle Adjustable:** (figure 11). Gradually apply rotational force on handle of TI until sharp audible snap is heard. Stop applying force at this point.

**NOTE**

**Torque Wrench, Audible, Preset Torque:** (figure 12). Note torque value setting on handle of TI. Gradually apply perpendicular force on handle of TI until audible (snap) signal is heard. Stop applying force at this point.

**NOTE**

**Clutch-Type Torque Screwdrivers:** Turn TI in clockwise direction and observe that torque cell indication remains at 0. Remove TI from torque cell. Insert TI into appropriate torque cell, using adapter (part of tool set) as required. Set screwdriver for cardinal point in (1) above. Gradually apply rotational force on handle of TI until clutch automatically releases. Stop applying force at this point.

**NOTE**

**Direct-Reading Torque Screwdrivers:** (figure 13). Perform 9 below.

(4) Slowly release force and record reading on indicator. Remove TI from torque cell. Press the **↵** soft key to reset the force/torque indicator (snap wrenches only). Press the **→0←** soft key to zero force/torque indicator.

(5) Repeat technique of (4) above with the applicable note two more times.

(6) Compute average reading of indications recorded in (4) and (5) above. If average reading is not within limits specified in table 1 for TI being calibrated, perform **b** below.

(7) Repeat technique of (3) through (6) above at TI cardinal points of 60 and 100 percent of maximum range.

**b. Adjustments.** Adjust in accordance with manufacturer's instruction manual.

**NOTE**

Some torque wrenches do not have adjustments.

**9. Accuracy (12 in-lbs (192 in-oz) or less)**

**a. Performance Check**

(1) Attach TI with ranges of 12.5 in-lbs (200 in-oz) or less to torque tester.

(2) Slowly apply torque to TI in a clockwise direction for full-scale indication of TI. (Do not over-torque torque tester.)

(3) Slowly release torque until only tare torque of TI is applied.

(4) Repeat (2) and (3) above two more times.

(5) Compute average reading of indications in (2) and (4) above. If average reading is not within limits specified in table 1 or appendix A for TI being calibrated, perform **b** below.

**b. Adjustments.** Adjust in accordance with manufacturer's instruction manual.

**NOTE**

Some torque wrenches/screwdrivers do not have adjustments.

**10. Final Procedure**

**a.** Deenergize and disconnect all equipment.

**b.** Unless otherwise specified by TI manufacturer, set audible (micrometer-type barrel) indicating torque wrenches at 20 percent of maximum range before storage.

**c.** Replace TI in its protective case.

**NOTE**

Calibration of a torque wrench/screwdriver in both clockwise and counterclockwise directions will be affixed with red tape overstamped with CW/CCW to identify calibration in both directions.

**d.** Annotate and affix DA label/form in accordance with TB 750-25.





APPENDIX A

Torque Screwdriver Accuracies

Model	Accuracy
0-100 INLB	±3%
0-100 INOZ	±3%
0-12 INLB	±3%
0-1600 INOZ	±3%
0-16 INOZ	±3%
0-20 INLB	±3%
0-24 INOZ	±3%
0-25 INLB	±3%
0-30 INLB	±3%
0-32 INOZ	±3%
0-35 INLB	±3%
0-36 INLB	±3%
0-40 INLB	±3%
0-60 INLB	±3%
0-6 INLB	±3%
0-75 INLB	±3%
0-96 INOZ	±3%
1001SMO	±3%
15SAPT8B	±3%
2-100 INOZ	±3%
2-35 INLB	±3%
2-36 INLB	±3%
20-100 INOZ	±3%
24 INOZ	±3%
32130	±3%
36/4	±3%
361SM	±3%
4-36 INLB	±3%
401SM	±3%
4 INLB	±3%

APPENDIX A

Torque Screwdriver Accuracies - Continued

Model	Accuracy
5-35 INLB	±3%
64-1007	±3%
810587	±6%
810588-4	±3%
8299-38	±3%
8710-1617	±3%
A100	±3%
B25	±3%
CAL100	±3%
CAL30	±3%
CAL30A	±3%
CAL35	±3%
CAL36/4	±3%
EMTSK36/4	±3%
EXACTORQ100	±3%
GS170	±3%
JOMAX50	±3%
MAL500-3	±3%
MIL-W26497	±3%
MTW-50SA	±3%
PM5	±3%
QDRIVER4	±6%
QDRIVER4P	±6%
QTS135	±3%
QTSP135	±3%
SA054B8	±3%
SL25	±3%
SL50	±3%
T30	±3%
TLS0135	±3%

APPENDIX A

Torque Screwdriver Accuracies - Continued

Model	Accuracy
TQS025	±3%
TQS2	±3%
TQS2.5FU	±3%
TQS2FU	±3%
TQS6FUA	±3%
TQSC6	±3%
TQSC6A	±3%
TQSC6GV	±3%
TQSR1FUA	±3%
TS100	±6%
TS30	±6%
TS35	±6%
TSK36	±3%
TT50FH	±3%



By Order of the Secretary of the Army:

GEORGE W. CASEY, JR.  
*General, United States Army*  
*Chief of Staff*

Official:



JOYCE E. MORROW  
*Administrative Assistant to the*  
*Secretary of the Army*

0710802

Distribution:

To be distributed in accordance with the initial distribution number (IDN) 342077, requirements for calibration procedure TB 9-5120-202-24.



### Instructions for Submitting an Electronic 2028

The following format must be used if submitting an electronic 2028. The subject line must be exactly the same and all fields must be included; however, only the following fields are mandatory: 1, 3, 4, 5, 6, 7, 8, 9, 10, 13, 15, 16, 17, and 27.

From: "Whomever" [whomever@redstone.army.mil](mailto:whomever@redstone.army.mil)  
To: <2028@redstone.army.mil

Subject: DA Form 2028

1. **From:** Joe Smith
2. **Unit:** home
3. **Address:** 4300 Park
4. **City:** Hometown
5. **St:** MO
6. **Zip:** 77777
7. **Date Sent:** 19-OCT -93
8. **Pub no:** 55-2840-229-23
9. **Pub Title:** TM
10. **Publication Date:** 04-JUL-85
11. **Change Number:** 7
12. **Submitter Rank:** MSG
13. **Submitter FName:** Joe
14. **Submitter MName:** T
15. **Submitter LName:** Smith
16. **Submitter Phone:** 123-123-1234
17. **Problem:** 1
18. **Page:** 2
19. **Paragraph:** 3
20. **Line:** 4
21. **NSN:** 5
22. **Reference:** 6
23. **Figure:** 7
24. **Table:** 8
25. **Item:** 9
26. **Total:** 123
27. **Text**

This is the text for the problem below line 27.







